

Design Guidelines

*Downtown Development Overlay
District Perry, Georgia
Adopted: January 5, 2023*



INTRODUCTION CONTENTS

Preface

[PG 3] Provides a summary of the purpose and intent of local design guidelines; and the establishment of a design review board.

Intent and Purpose

Main Street Advisory Board (MSAB)

Design Review Process

[PG 4-6] Outlines the design review process, providing a flow chart and answers to the most common questions.

Downtown Development Overlay District

Common Questions

Administration and

Design Review Flow Chart

Standards & Guidelines

[PG 7-8] Introduces the national guidelines from which these guidelines are developed.

Secretary of the Interior's Standards

General Guidelines

PREFACE

Intent and Purpose

The purpose of this booklet is to provide information on local preservation measures, the design review process, and the visual character which defines Perry's downtown. The remainder of the booklet outlines design guidelines for commercial areas. The guidelines listed and illustrated herein are designed to assist decision makers --- property owners, developers, contractors, and board members --- in developing design solutions which promote the development of downtown Perry while maintaining its historic character.

Main Street Advisory Board

The Land Management Ordinance establishes the Main Street Advisory Board (MSAB), the volunteer board which serves as part of the planning functions of the City of Perry. The MSAB is charged with the responsibility of the design review process, and public education and awareness. The Board consists of seven appointed members, who serve three-year terms without monetary compensation.





Perry Downtown Boundary



Where Georgia comes together.

Legend

-  Current Downtown
-  Development District Parcels

The Common Questions

What is design review?

The Land Management Ordinance provides for a design review process. Design review consists of the evaluation of any proposed exterior work upon a property within a designated district. Both minor and extensive projects must be reviewed and approved prior to beginning work. The design review process is often triggered by a building permit application; however, building permits can not be issued until design review is complete. Although some types of work projects, such as installation of a walkway or a satellite dish, may not require a building permit, design review is still required.

Which properties require design review?

All properties in the Downtown Development Overlay District require design review. The map on page 4 identifies all properties in the Downtown Development Overlay District. A call to the Community Development office can confirm whether or not a property is in the district.

What type of work requires design review?

All work involving a change to an exterior feature of a property requires design review. Projects that physically alter the property include but are not limited to: changes in site or setting, repair or rehabilitation, relocation or demolition, and new construction or additions.

Neither interior alterations nor a change in the use of the property require design review. Design review applies only to the external aspects of the property and regulates neither zoning nor land use. Ordinary maintenance does not require design review.

What is a Certificate of Appropriateness?

When planning a work project, an owner must submit a completed application for a Certificate of Appropriateness (COA). Applications are available from and should be submitted to the Community Development office. The deadline for applications is the 15th day of the month prior to the MSAB meeting held on the first Thursday of each month. Please contact the Community Development office for regular meeting dates and times. Utilizing design guidelines and the general standards for the rehabilitation of historic properties, the MSAB must decide to approve or deny the application. If the application is approved, a Certificate of Appropriateness is issued and design review is complete.

What should an application include?

In order that the Board may make an informed decision, completed applications must be accompanied by support materials. Illustrations may include site plans, elevations, and floor plans drawn to a standard architectural scale, e.g. 1/4 inch equals one foot. Photographs of the building, site, and neighboring properties are also helpful. Support materials may differ according to the type and size of the project. The application and support materials must be submitted at the same time.

What could happen if work begins before design review?

If work is initiated prior to approval of a COA application or to obtaining a building permit, a stop work order may be issued. If these requirements are not met, the property owner may face fines or an order to restore the original condition of the property.

Where can additional assistance be found?

This booklet outlines design guidelines which are useful for project planning; however, the MSAB does not actually develop plans or designs. Property owners are encouraged to review the design guidelines set forth in the booklet prior to planning any rehabilitation work or new construction. Familiarity with the design guidelines will facilitate design review. For information concerning the process or for assistance with the preparation of the application, contact the Community Development office at (478)988-2720.

Are there any other review procedures?

Review of projects by the MSAB may not be the only review required before work may proceed. Other city departments and commissions may be required to examine a project for compliance with existing zoning regulations, building codes, and sign or landscape ordinances.

DESIGN REVIEW PROCESS

Administration

The Main Street Advisory Board will review applications for Certificate of Appropriateness for consistency with these guidelines. The Board will make a recommendation to the Community Development office whether to approve, approve with conditions, or deny a Certificate of Appropriateness.

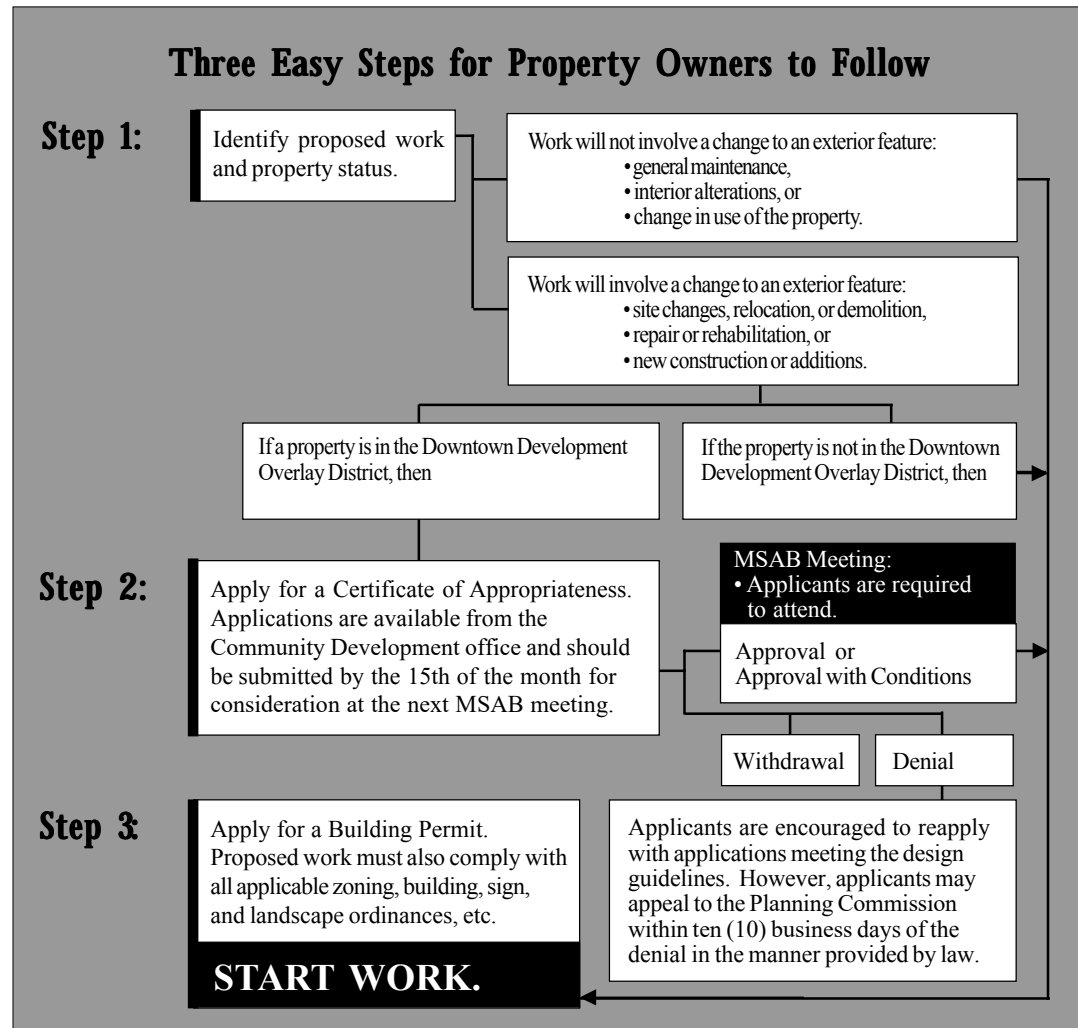

Secretary of the Interior's Standards for Rehabilitation

Rehabilitation is defined as the act or process of making possible a compatible use for a property through repair, alterations, and additions while preserving those portions of features which convey its historical, cultural, or architectural values.

The following Standards are to be applied to specific rehabilitation projects in a reasonable manner, taking into consideration economic and technical feasibility.

- ▶ A property shall be used for its historic purpose or be given a new use that requires minimal change to its distinctive materials, features, spaces, and spatial relationships.
- ▶ The historic character of a property shall be retained and preserved. The removal of distinctive materials or alteration of features, spaces, and spatial relationships that characterize a property shall be avoided.
- ▶ Each property shall be recognized as a physical record of its time, place, and use. Changes that create a false sense of historical development, such as adding conjectural features or elements from other historic properties, shall not be undertaken.
- ▶ Changes to a property that have acquired historic significance in their own right shall be retained and preserved.
- ▶ Distinctive materials, features, finishes, and construction techniques or examples of craftsmanship that characterize a property shall be preserved.
- ▶ Deteriorated historic features shall be repaired rather than replaced. Where the severity of deterioration requires replacement of a distinctive feature, the new feature shall match the old in design, color, texture, and where possible, materials. Replacement of missing features shall be substantiated by documentary and physical evidence.
- ▶ Chemical or physical treatments, if appropriate, shall be undertaken using the gentlest means possible. Treatments that cause damage to historic materials shall not be used.
- ▶ Archeological resources shall be protected and preserved in place. If such resources must be disturbed, mitigation measures shall be undertaken.
- ▶ New additions, exterior alterations, or related new construction shall not destroy historic materials, features, and spatial relationships that characterize the property. The new work shall be differentiated from the old and shall be compatible with the historic materials, features, size, scale and proportion, and massing to protect the integrity of the property and its environment.
- ▶ New additions and adjacent or related new construction shall be undertaken in such a manner that , if removed in the future, the essential form and integrity of the historic property and its environment would be unimpaired.

STANDARDS & GUIDELINES

design guidelines

Developed for the Main Street Advisory Board, the design guidelines within this booklet are based upon the visual character of Perry's downtown. The Board also considers the *Secretary of the Interior's Standards for Rehabilitation*, which present general guidelines for the rehabilitation of historic buildings.

rehabilitation

Rehabilitation is a sensitive approach to historic design and materials during simple repairs and during alterations. Rehabilitation permits contemporary use while preserving those features of the building which are significant to its historic character. Such character-defining features are an integral part of each building and contribute to the visual character of the surrounding area.

new construction

New construction can be compatible with historic properties and buildings through attention to design and materials. In addition, existing non-historic buildings can increase their compatibility by following similar design considerations during renovation projects. Sensitive design of new construction is imperative when planning either new buildings, additions to existing buildings, or renovating intrusive non-historic buildings.

special consideration

Institutional properties, both public and private, are often the exception to the rule. While historic institutional properties should follow the same guides for rehabilitation, new institutional buildings may vary from the surrounding district in some respects to distinguish the property's civic importance. For example, a new government building may utilize a deeper setback than surrounding historic buildings while using a similar exterior material.

demolition

The demolition of historic buildings diminishes the built environment and creates unnecessary waste. Demolition of a historic structure is only approved in very rare, specific, and narrowly defined circumstances, and no demolition occurs without approval of post-demolition plans. The aspects the commission consideration include but are not limited to: age, integrity, significance, condition, alternatives, and overall effect.

relocation

Relocation falls into one of three categories: 1) removing a structure from a historic district, 2) moving a structure into a historic district, or 3) moving a structure to a different location within a historic district. Different criteria are applied to each. Proposed relocation out of a historic district constitutes a loss and therefore, demolition guidelines apply. New construction guidelines apply for proposed relocations into a historic district. For proposed relocations within a historic district, the following considerations apply: age, previous relocation, compatibility of the new site, significance, condition, alternatives, and overall effect.

COMMERCIAL CONTENTS

Topics/Issues

Rehabilitation

[PG 10-25] Reviews the elements of historic construction that contribute to architectural style and building form for non-residential properties and areas. Highlights common mistakes to avoid and provides examples of changes subject to the design review process.

Roofs - Shape & Features

Materials

Details

Storefronts

Windows

Doors

Awnings

Additions

New Construction

[PG 26-35] Discusses the most significant aspects of new construction and its relationship to and potential impact upon the existing built environment for non-residential properties and areas. Highlights common mistakes to avoid.

Placement

Scale

Form

Openings

Materials & Details

Site & Setting

[PG 36-41] Outlines the accessory features commonly located on historic properties and reviews their relationship to the historic building for non-residential properties and areas. Highlights common mistakes to avoid and provides examples of changes subject to the design review process.

Walls & Fences

Signs

Modern Features

GOAL:

The primary goal is to maintain the original form of the building, especially as seen from the public view.

Actions to achieve the goal:

- ▶ Maintain the existing pitch and shape of the roof as seen from the public view. Changes hidden by existing parapets may be allowed.
- ▶ Replace existing roofing materials with the same type of roofing material. Changes hidden by existing parapets may be allowed.
- ▶ Secondary features and character defining materials which contribute to design should be retained.
- ▶ Maintain historic chimneys.
- ▶ Preserve historic skylights whenever possible.



Roof shape refers to the overall roof type and pitch. Roof features are any items attached to the roof, including parapets.

Glossary terms:

Character defining. An element whose design and material is associated with the age and style of a building and helps define its architectural style (e.g. tile roofing on Mission Style buildings).

Facade.

The front elevation or “face” of a building.

Pitch.

A term which refers to the steepness of roof slope.

Parapet.

A low protective wall located at the edge of a roof.

Public view.

That which can be seen from any public right-of-way.

Routine maintenance.

Any action performed in order to preserve a historic property including minor replacement of material with like material providing no change is made to the appearance of the structure or grounds.

- more terms found in the Glossary, p. 42

Changes requiring a COA

Examples:

- * Changing the pitch or shape of a roof.
- * Reroofing a roof with a material which is different than the existing material.
- * Removing or adding chimneys.
- * Stuccoing brick chimneys.
- * Repointing parapets or chimneys.

Changes not requiring a COA

Examples:

- * Reroofing a roof with the same material.
- * Repairing flashing.
- * Repairing existing gutters.

Common Mistakes

- ▶ *Replacing a flat roof with a gable roof which is not hidden by the parapet.* [A]
- ▶ *Removing ornamental roof features.* [B]
- ▶ *Repointing parapets with cement or not matching the original mortar joints.*
- ▶ *Adding a story to the building.* [C]

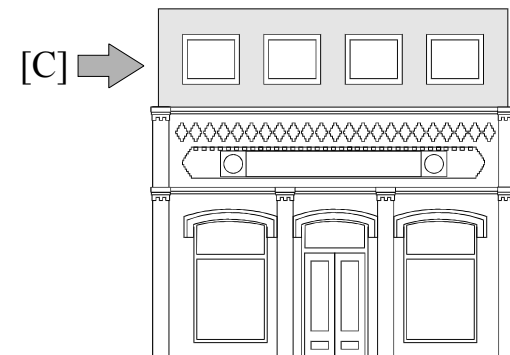
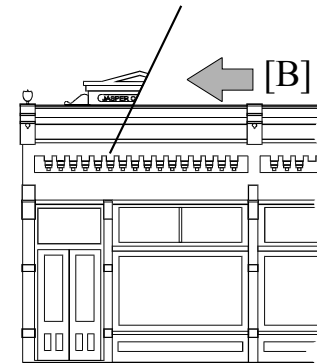
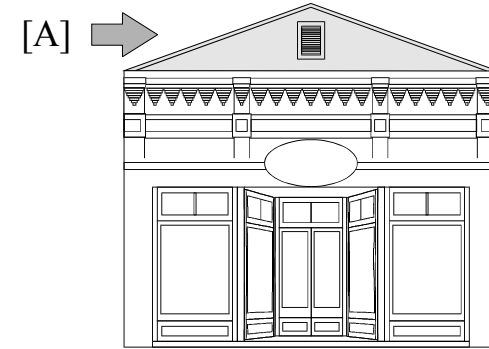

GOAL:

The primary goal is to maintain the texture created by historic exterior materials.

Actions to achieve the goal:

- ▶ Maintain historic exterior materials.
- ▶ Leave unpainted historic masonry unpainted and uncoated.
- ▶ Repair damaged exterior materials in-kind and only in the area of damage, rather than total replacement.
- ▶ Use a historic mortar mix [formula found in the glossary] and match the original mortar joints when repointing brick. Use a qualified professional mason.
- ▶ Use the gentlest means possible to clean exterior materials.



Materials, in this instance, refers to the materials of the exterior walls.

Glossary terms:

Bond.

A term used to describe the various patterns in which brick is laid.

Gentlest means possible.

The least abrasive, intrusive, damaging means of preserving historic material.

Historic mortar mix.

There are designated five mortar types. Typically, the repointing mortar for historic buildings will be a Type O or K mortar. Mortar specifications permit a range of proportions, but typical proportions by volume are: Type O - 1 part portland cement, 2 parts hydrated lime, and 9 parts sand; Type K - 1 part portland cement, 4 parts hydrated lime and 15 parts sand.

In-kind.

Using the exact same material when replacing a damaged element (e.g. using a wood element to replace a wood element).

Reveal.

The vertical profile created by the lap of siding, window casings, muntins, door surrounds, etc.

Siding. The exterior wall covering or sheathing of a structure.

- more terms found in the Glossary, p. 42

Changes requiring a COA

Examples:

- * Removing siding material (historic or non-historic).
- * Residing a building.
- * Painting unpainted masonry.
- * Entirely removing paint from a building.

Changes not requiring a COA

Examples:

- * Repainting a building.
- * Preparing surfaces for repainting.

Common Mistakes

- ▶ *Placing vinyl siding, aluminum, exterior insulating finishing systems (E.I.F.S. or synthetic stucco), or another type of synthetic siding on a historic building. [A]*
- ▶ *Sandblasting exterior surfaces which will remove historic brick's protective exterior. [B]*
- ▶ *Painting or "waterproof" coating unpainted masonry. "Waterproofing" rarely corrects water infiltration and often worsens damage by trapping the moisture.*

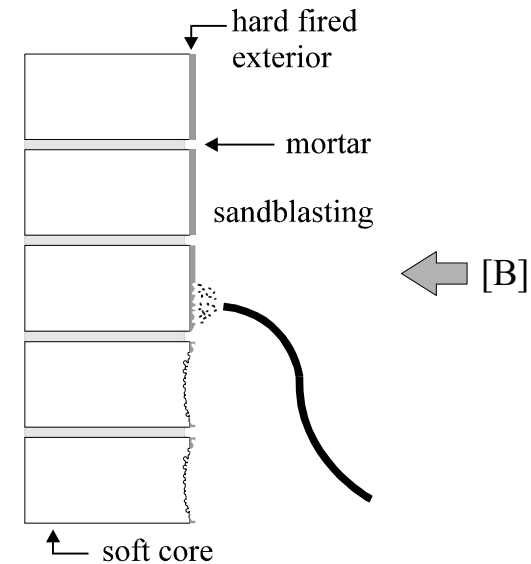
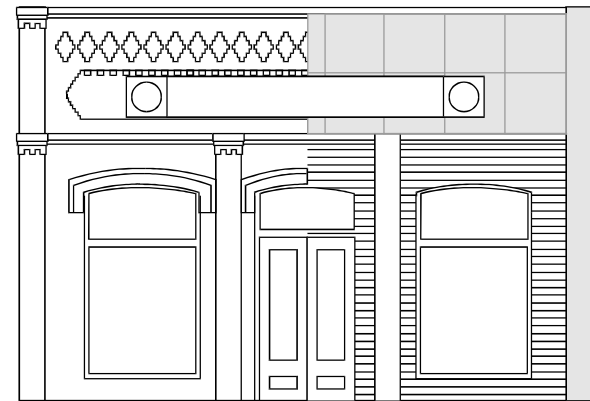

GOAL:

The primary goal is to maintain detail elements typical to commercial buildings, many of which impart a specific architectural style.

Actions to achieve the goal:

- ▶ Maintain and preserve historic details.
- ▶ Replace damaged details with details of matching material and matching design.
- ▶ Restore missing details when documentation of those elements are available.

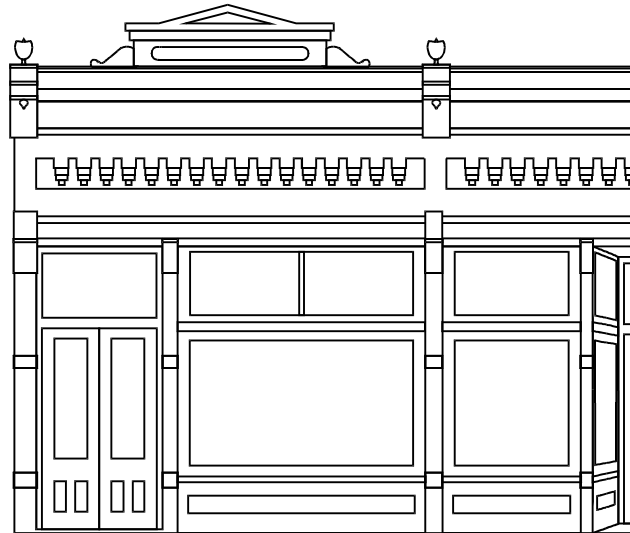

Details refers to those components on the exterior of the building which serve to embellish the structure. Details are often related to a specific architectural style.

Glossary terms:

Bracket.

A decorative support feature located under eaves or overhangs.

Capital.

Topmost member of a column or pilaster.

Cornice.

The uppermost, projecting part of an entablature, or feature resembling it.

Dentil.

One of a series of small, square, tooth or block-like projections forming a molding.

Documentation.

Evidence of missing elements or configurations of buildings such as architectural plans, historic photographs, or “ghosts” of missing elements.

Pilaster.

A pier attached to a wall, often with capital and base.

- more terms found in the Glossary, p. 42

Changes requiring a COA

Examples:

- * Removing architectural details.
- * Adding architectural details.

Changes not requiring a COA

Examples:

- * Repairing architectural details.
- * Repainting architectural details.

Common Mistakes

- ▶ *Adding architectural details where none existed before. [A]*
- ▶ *Removing details from a building. [B]*
- ▶ *Adding shutters which do not fit the windows. [A]*
- ▶ *Using stock, out of scale, details rather than matching the original details.*

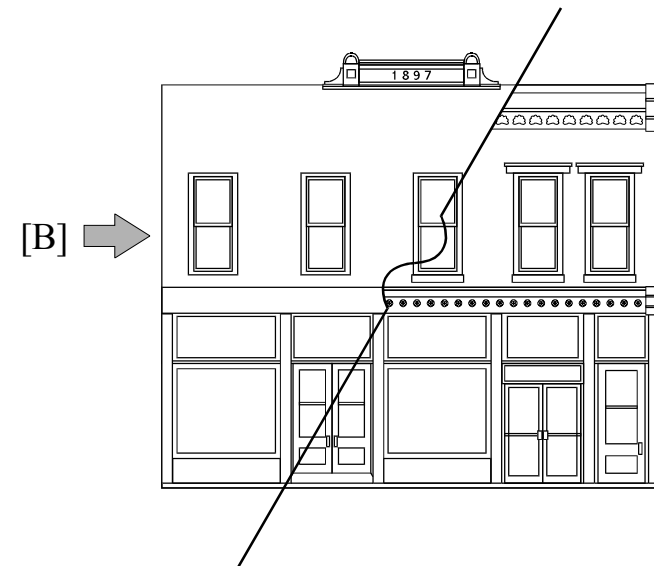
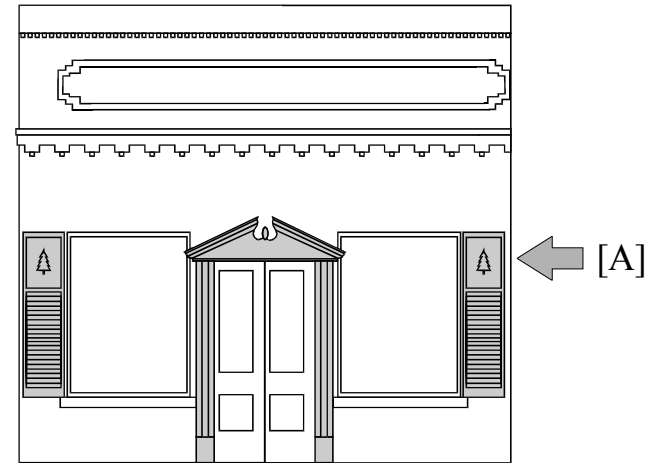

16 REHABILITATION STOREFRONT

GOAL:

The primary goal is to maintain the original materials and configuration of the storefront.

Actions to achieve the goal:

- ▶ Maintain historic cast iron columns.
- ▶ Maintain transoms. Reopening previously covered transoms is encouraged.
- ▶ Maintain original window components replacing only damaged portions.
- ▶ Maintain the high ratio of window to wall in display area. Restoring previously enclosed display windows based on documentation or traditional design is encouraged.
- ▶ Maintain original bulkheads and if entire replacement is necessary, use materials similar to the original.

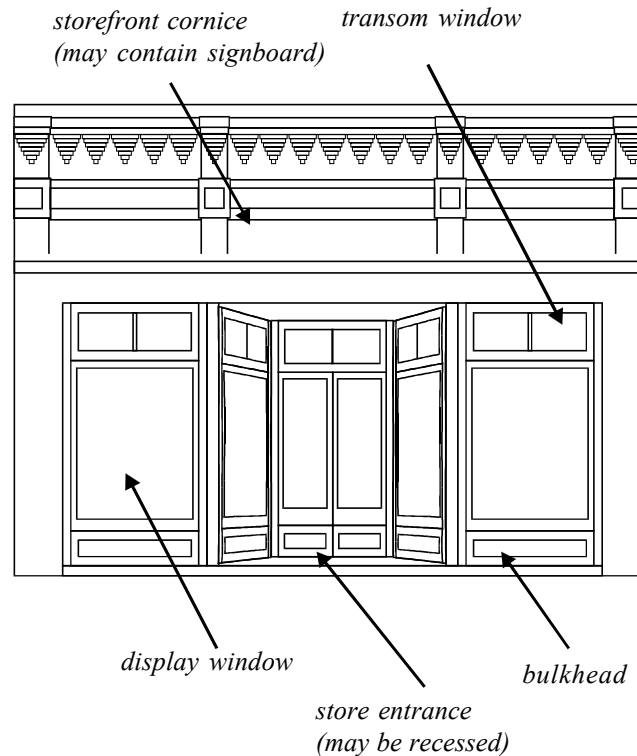

Storefront refers to the first floor of historic commercial buildings usually consisting of an entrance, display windows, transoms, and bulkheads.

Glossary terms:

Bulkhead.

The panel between framing members and beneath the display windows in a storefront; also known as a kickpanel or kickplate.

Cornice.

The uppermost, projecting part of an entablature, or feature resembling it.

Documentation.

Evidence of missing elements or configurations of buildings such as architectural plans, historic photographs, or “ghosts” of missing elements.

In-kind.

Using the exact same material when replacing a damaged element (e.g. using a wood element to replace a wood element).

Transom.

A small operable or fixed window located above a window or door.

- more terms found in the Glossary, p. 42

Changes requiring a COA

Examples:

- * Replacement of the existing storefront.
- * Replacement of a nonhistoric storefront.
- * Replacement of the bulkheads.
- * Replacement of all glass.

Changes not requiring a COA

Examples:

- * Repair of broken glass with clear glass.

Common Mistakes

- ▶ *Replacing wooden bulkheads with brick.* [A]
- ▶ *Replacing display windows with smaller or more elaborate windows.* [B]
- ▶ *Replacing display windows with wall surface.*
- ▶ *Placing window air conditioners in transom windows.*
- ▶ *Covering transom windows with plywood.* [C]

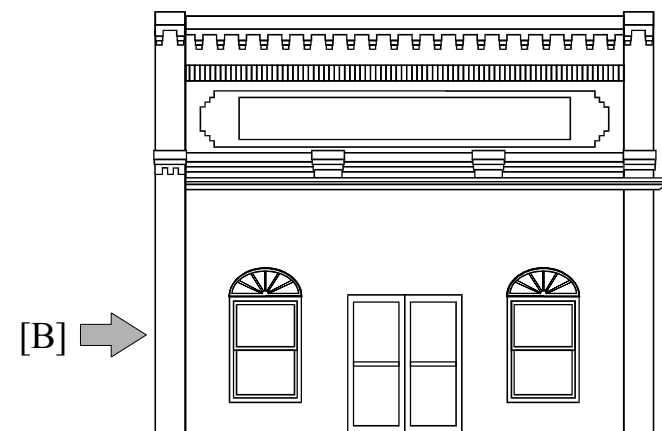
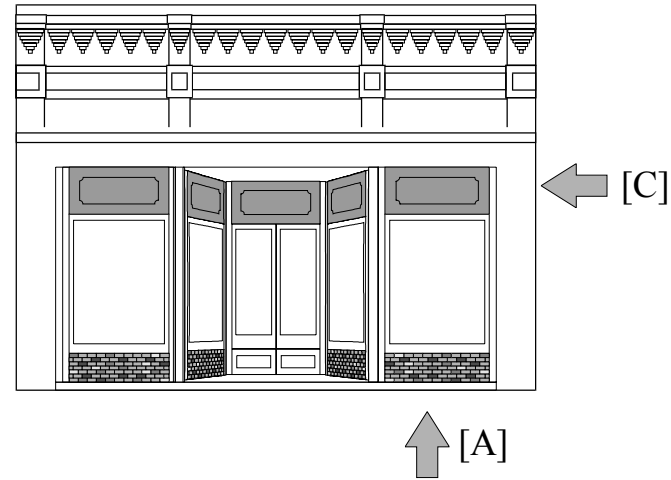

GOAL:

The primary goal is to maintain the historic windows, their design, and their placement.

Actions to achieve the goal:

- ▶ Maintain and preserve historic windows.
- ▶ Repair damaged portions of historic windows rather than replacing them in total.
- ▶ Historic windows damaged beyond repair should be replaced with windows of matching materials, design, pane configuration, and muntin profile. Aluminum clad wood windows may be allowed on upper story windows, but not windows of vinyl or aluminum construction.
- ▶ Maintain the historic window configuration and dimensions.
- ▶ New windows on side and rear elevations should relate to historic windows in the following ways:
 - a) use matching materials,
 - b) be of matching or similar size, and
 - c) use matching or similar design.
- ▶ Storm windows must match the color of the window frame and obscure the window as little as possible.



Windows refers to glazed openings in the exterior walls of the building. (see also *Storefronts*, p. 30)

Glossary terms:

Beyond repair.

When such a large portion of an element is damaged that repair becomes infeasible, generally, but not specifically, more than 50%.

Double hung window.

A window having two sashes, one sliding vertically over the other.

Fenestration.

The arrangement of window openings in a building.

Lintel.

A horizontal beam over a door or window which carries the weight of the wall above; usually made of stone or wood.

Muntin.

A secondary framing member to divide and hold the panes of glass in a window.

Sash.

The portion of a window that holds the glass and which moves.

Sill.

The horizontal member located at the top of a foundation supporting the structure above; also the horizontal member at the bottom of a window or door.

Solid-to-void.

The total area of wall in comparison to the total area of openings on an elevation.

- more terms found in the *Glossary*, p. 42

Changes requiring a COA

Examples:

- * Removing and replacing windows.
- * Filling in existing window openings.
- * Adding new window opening.
- * Adding new storm windows and screens.

Changes not requiring a COA

Examples:

- * Replacing broken window glass.
- * Repairing damaged portions of existing sashes.
- * Weather-stripping, caulking, painting and other general maintenance.
- * Adding clear UV coating.

Common Mistakes

- ▶ *Replacing viable (deteriorated but repairable) historic windows with new windows, even similar looking windows.*
- ▶ *Replacing windows with flat muntins with no profile.*
- ▶ *Replacing windows with tinted glass, single panes, or smaller windows. [A]*
- ▶ *Reducing the size of windows. [B]*
- ▶ *Infilling windows. [C]*
- ▶ *Adding storm windows which obscure the historic window.*

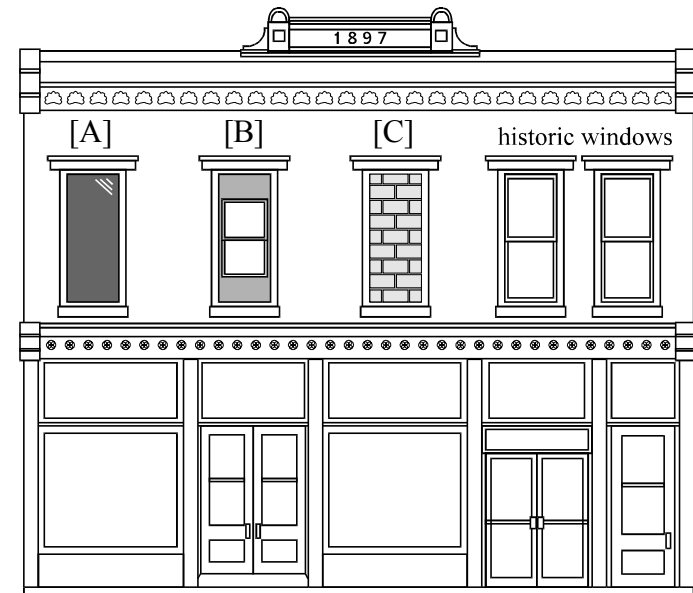

GOAL:

The primary goal is to maintain the historic doors, their design, and their placement.

Actions to achieve the goal:

- ▶ Maintain and preserve historic doors and surrounding features.
- ▶ Repair damaged portions of historic doors rather than replacing the door in total.
- ▶ Historic doors damaged beyond repair should be replaced with doors that match in material and design.
- ▶ Maintain the historic door placement on the facade including entrances to upper floors.
- ▶ Replace non-historic doors with a replication of the historic door (if documentation exists) or a design typical for the age of the building.

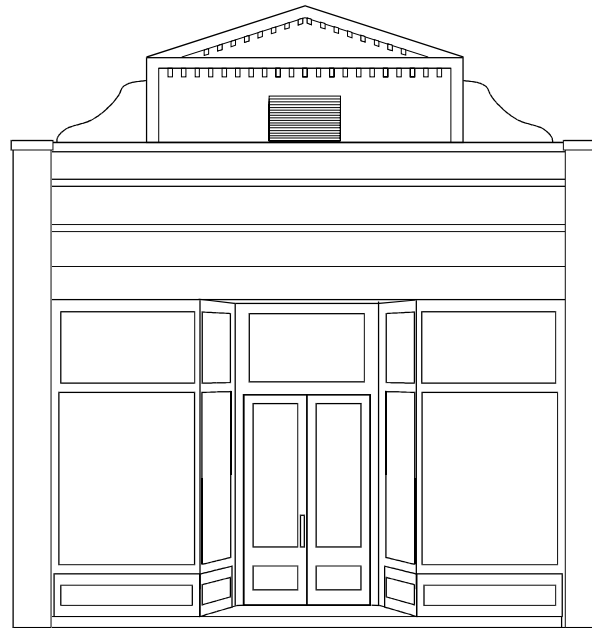

Doors refers to entrances into the building including the doorway and features around the doorway. (see also *Storefronts*, p. 30)

Glossary terms:

Beyond repair.

When such a large portion of an element is damaged that repair becomes infeasible, generally, but not specifically, more than 50%.

Facade.

The front elevation or “face” of a building.

French door.

A door made of many glass panes, usually used in pairs and attached by hinges to the sides of the opening in which it stands.

Mullion. A heavy vertical divider between windows or doors.

Pediment.

A triangular crowning element forming the gable of a roof; any similar triangular element used over windows, doors, etc.

Surround.

An encircling border or decorative frame, usually around a window or door.

Transom.

A small operable or fixed window located above a window or door.

- more terms found in the Glossary, p. 42

Changes requiring a COA

Examples:

- * Removing and replacing doors.
- * Filling in existing door openings.
- * Adding new door openings.
- * Adding new storm /screen doors.

Changes not requiring a COA

Examples:

- * Repairing damaged portions of existing doors.
- * Weather-stripping, caulking, painting and other general maintenance.

Common Mistakes

- ▶ *Replacing viable (deteriorated but repairable) historic doors with new doors, even similar looking doors.*
- ▶ *Using a door with a residential appearance. [A].*
- ▶ *Adding or removing doors on the facade.*
- ▶ *Adding sidelights, transoms, fanlights, or other features where none existed before. [B]*

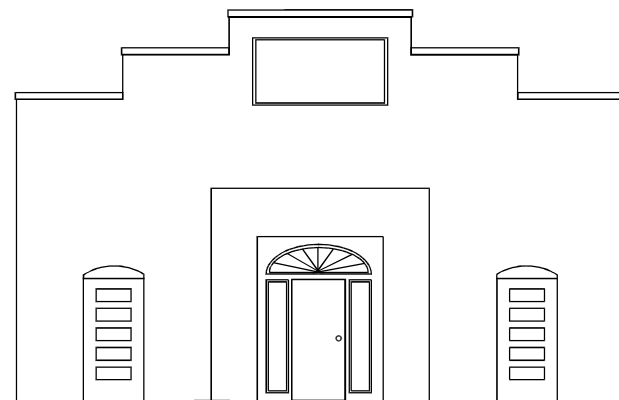
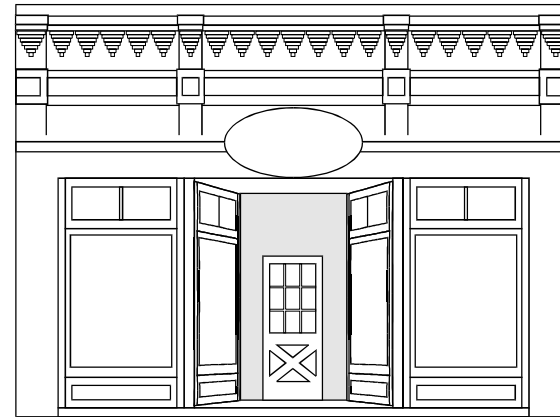

22 REHABILITATION AWNINGS

GOAL:

The primary goal is to promote the use of traditional form and design for awnings and canopies.

Actions to achieve the goal:

- ▶ Maintain historic awnings and canopies.
- ▶ Use canvas for awning materials.
- ▶ Match awnings shape to the shape of the window or door opening.
- ▶ Fit awning within the frame of the window or doorway without covering architectural detail.
- ▶ Traditional shed-style, sloping, fabric/canvas awnings are encouraged.

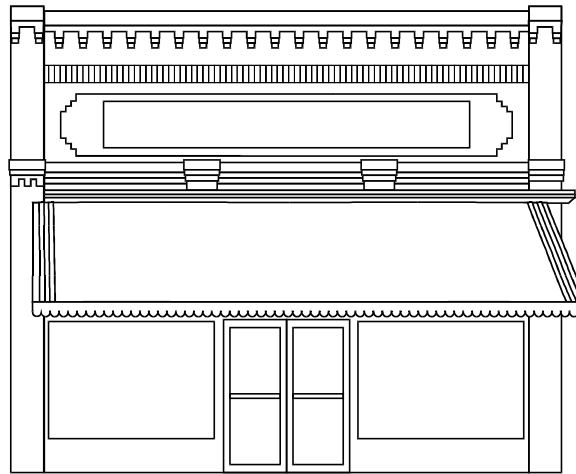

Awnings refers to elements projecting from the building which provide shade to the adjacent area. Canopies are included.

Glossary terms:

Awning.

A sloped projection supported by a frame attached to the building facade or by simple metal posts anchored to the sidewalk.

Canopy.

A flat projection from the building facade or attached to the building facade to shelter the storefront and pedestrian traffic.

Cornice.

The uppermost, projecting part of an entablature, or feature resembling it.

- more terms found in the Glossary, p. 42

Changes requiring a COA

Examples:

- * Removing awnings.
- * Adding a new awnings or canopies.

Changes not requiring a COA

Examples:

- * Replacing awning canvas.
- * Repairing a metal awning.
- * Repainting a metal awning.

Common Mistakes

- ▶ *Using a rounded awning for a rectangular doorway or window. [A]*
- ▶ *Using an awning which does not match the dimension of the doorway or window. [B]*
- ▶ *Using barrel-style awnings. [C]*
- ▶ *Using flat projecting metal or rigid plastic awnings.*
- ▶ *Lighting awnings internally.*
- ▶ *Using a continuous awning across two buildings to join them as one business. [D]*
- ▶ *Constructing a front porch and balcony where none existed before.*

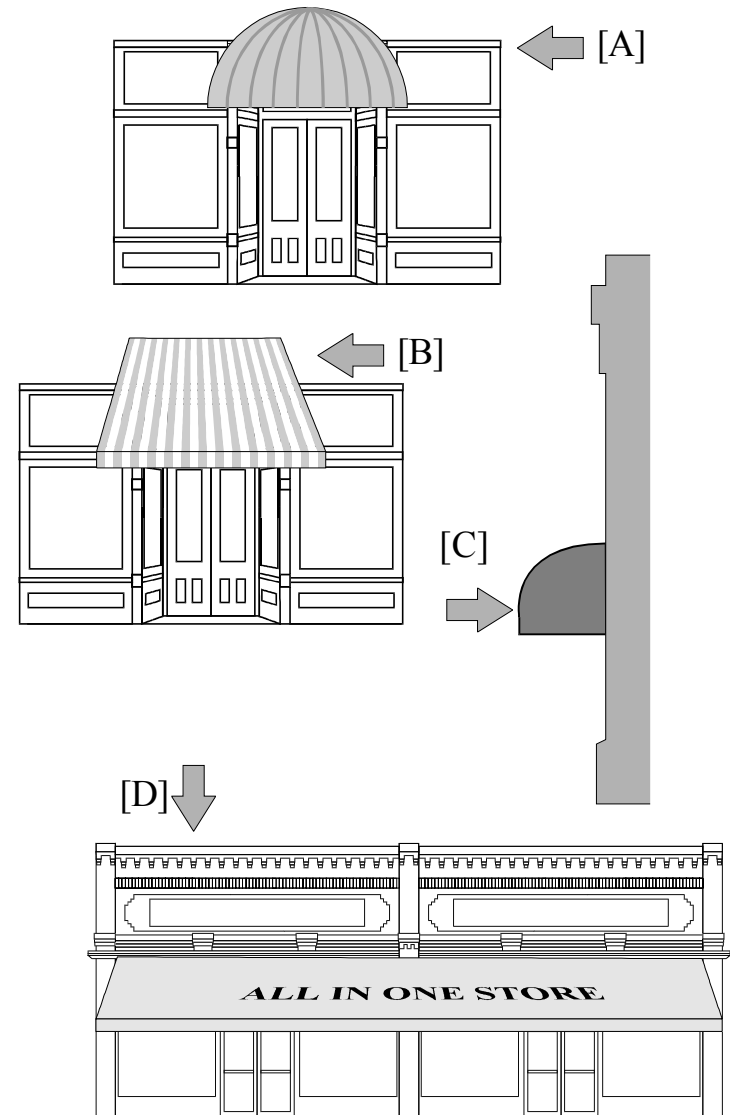

24 REHABILITATION ADDITIONS

GOAL:

The primary goal is to allow expansion while maintaining historic character.

Actions to achieve the goal:

- ▶ Additions should respect the original portion of the building by:
 - a) being placed away from the public view on the rear elevation or (for buildings not on the square) on a side elevation well behind the facade,
 - b) maintaining the form, orientation, and symmetry of the original structure,
 - c) creating a discernible break at the juncture with the original structure,
 - d) using matching or similar materials such as roofing and siding,
 - e) using matching or similar elements, such as windows, on side elevations and reserving more modern elements for the rear elevation,
 - f) using a degree of ornamentation equal to the original or less, and
 - g) being reversible with a limited loss of historic materials and elements.

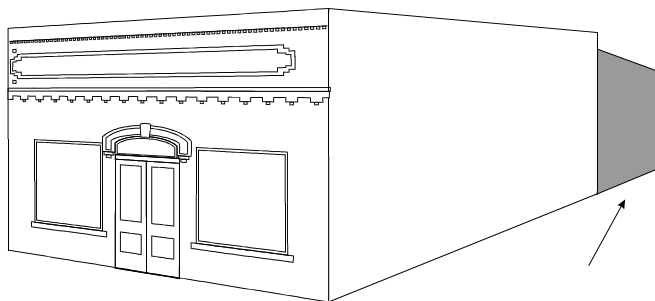

additions are best placed at the rear of the building

Additions refers to any increase in the square footage of a building.

Glossary terms:

Elevation.

Any of the external faces of a building.

Facade.

The front elevation or “face” of a building.

Public view.

That which can be seen from any public right-of-way.

Reversible.

Constructing additions or new elements in such a manner that if removed in the future original form and material would be largely unchanged.

Routine maintenance.

Any action performed in order to preserve a historic property including minor replacement of material with like material providing no change is made to the appearance of the structure or grounds.

Orientation.

The direction that the building (usually includes the primary entrance) faces.

- more terms found in the Glossary, p. 42

Changes requiring a COA

Examples:

- * Adding an addition to a building.
- * Removing an addition from a building.

Changes not requiring a COA

Examples:

- * Routine maintenance to existing additions.

Common Mistakes

- ▶ *Constructing the walls of the addition flush with the facade of the original structure. [A]*
- ▶ *Constructing an addition out of scale which greatly alters the original form of the building.*
- ▶ *Using incompatible materials or details on an addition. [B]*
- ▶ *Removing a large amount of original material to add an addition.*

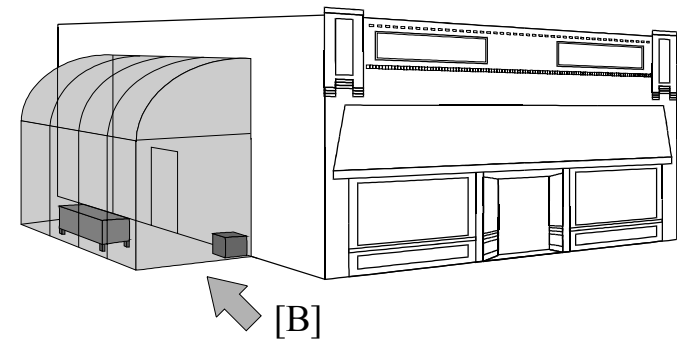
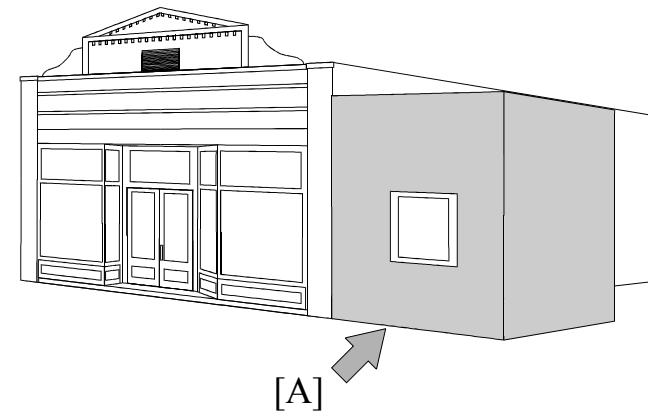

GOAL:

The primary goal is to follow the distinct rhythm established by the placement pattern of historic buildings in the district.

Actions to achieve the goal:

- ▶ New buildings should respect the placement of nearby historic buildings by being:
 - a) placed at a setback equal to or within 10 feet of that of nearby similar historic buildings or similar buildings within the district,
 - b) placed centrally on a lot with equal spacing on each side (party walls for buildings on Carroll Street, and on Jernigan Street and Ball Street between Main and Commerce Streets), and
 - c) oriented towards (or facing) the same street as nearby historic buildings.

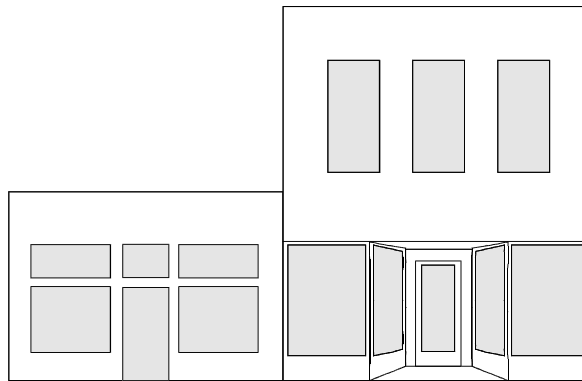

Downtown buildings are placed at the front of their lots (zero lot line) and share side walls with adjacent buildings (party walls).

Placement refers to how the building is located or situated upon its lot. Placement includes building setback, spacing, and orientation.

Glossary terms:

Nearby historic buildings.

The closest possible examples: 1) adjacent historic buildings, 2) historic buildings along the same street, 3) historic buildings within the immediate area, 4) historic buildings within the district.

Orientation.

The direction that the building (usually includes the primary entrance) faces.

Party wall.

A common, shared wall between two buildings; typical of downtown brick buildings.

Rhythm.

The pattern created by the relationship of elements along a street or on individual buildings (e.g. buildings to the open space or windows to wall space).

Setback.

A term used to define the distance a building is located from a street or sidewalk.

Spacing.

The distance between adjacent buildings.

- more terms found in the Glossary, p. 42

Notes/Revisions:

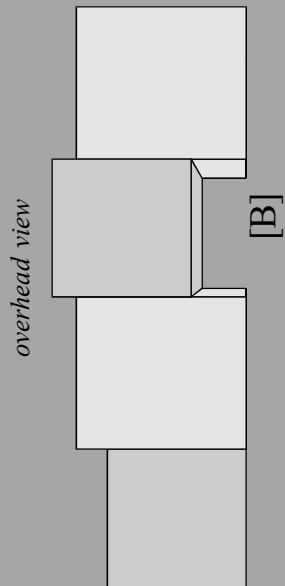
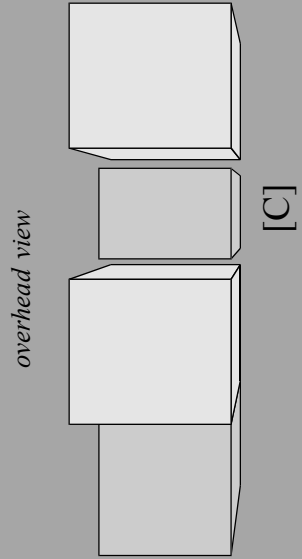

Common Mistakes

- ▶ Placement of a building facing a different street; corner or dual frontage properties should follow the example set by nearby historic corner properties. [A]
- ▶ Placement of a building not on the front lot line. [B]
- ▶ Placement of a building with side setbacks not party walls. [C]

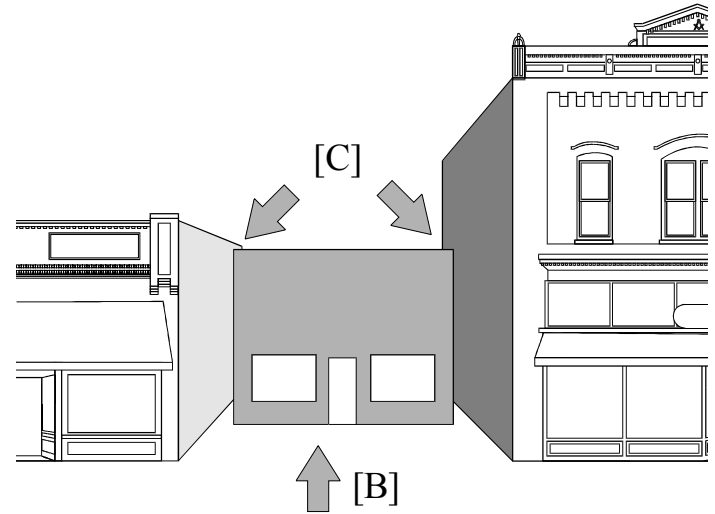
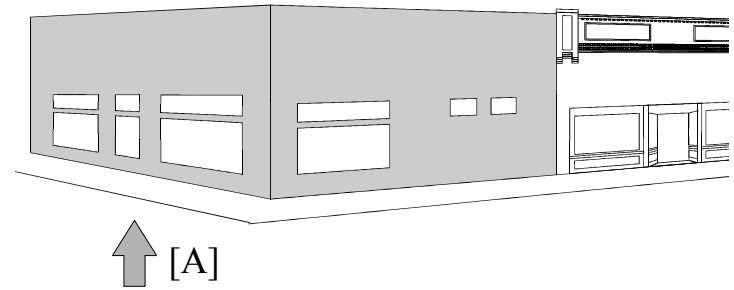

GOAL:

The primary goal is to follow the established dimensions of historic buildings within the district.

Actions to achieve the goal:

- ▶ New buildings should respect the existing scale of historic buildings by being:
 - a) either one-story or two-story depending upon the uniformity of height displayed by nearby historic buildings,
 - b) approximately the same width as nearby historic buildings of similar form, and
 - c) approximately the same depth of nearby historic buildings; for more depth, new buildings should follow the addition pattern of nearby historic buildings of similar scale.

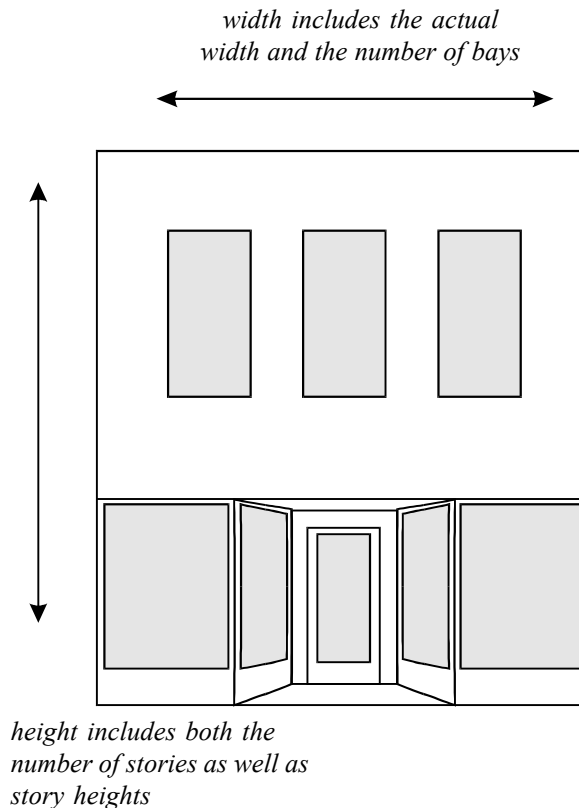

Scale refers to a building's dimensions - height, width, and depth - particularly in comparison to other buildings in the vicinity.

Glossary terms:

Bay.

The horizontal divisions of a building, defined by windows, columns, pilasters, etc.

Nearby historic buildings.

The closest possible examples: 1) adjacent historic buildings, 2) historic buildings along the same street, 3) historic buildings within the immediate area, 4) historic buildings within the district.

- more terms found in the Glossary, p. 42

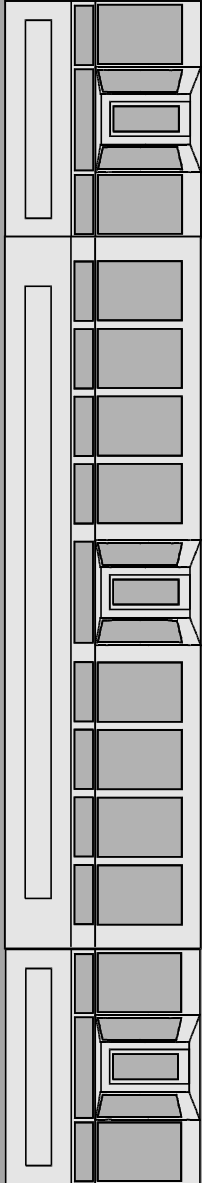

[C]

Common Mistakes

- ▶ *Constructing a building of more than two stories.*
[A]
- ▶ *Constructing a building out of scale with its neighbors even though the number of stories is equal.*
[B]
- ▶ *Constructing a building that is too wide and creates an inappropriate horizontal appearance.*
[C]

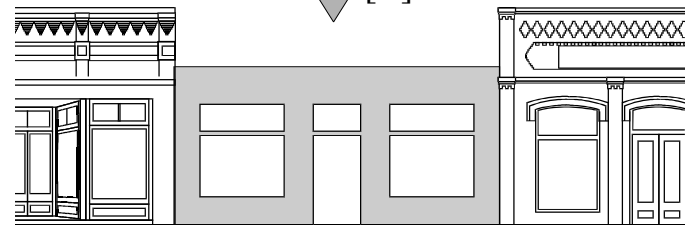

GOAL:

The primary goal is to follow the unique pattern of building forms found within the downtown district.

Actions to achieve the goal:

- ▶ New buildings should respect the existing form represented among historic buildings by:
 - a) using roof shapes, pitches, and parapets such as those on nearby similar historic buildings or similar buildings within the district,
 - b) creating a main block and using secondary blocks in a manner similar to that of nearby similar historic buildings or similar buildings within the district, and
 - c) having foundations of the similar height and pattern as similar historic buildings.

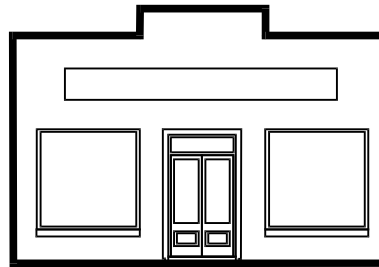

From the front each building creates a silhouette. On blueprints, this known as an "elevation."

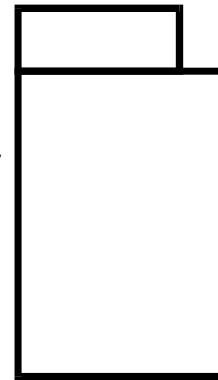

Each building creates a "footprint" created by the exterior walls of the building. On blueprints, this is called the "plan" or "floor plan."

Form refers to a building's overall shape and composition. Vertically there are three divisions of form: the roof, the body, and the foundation.

Glossary terms:

Main block.

The central mass of a building, generally excluding secondary blocks such as additional wings, projections, dormers, or porches.

Nearby historic buildings.

The closest possible examples: 1) adjacent historic buildings, 2) historic buildings along the same street, 3) historic buildings within the immediate area, 4) historic buildings within the district.

Pitch. A term which refers to the steepness of roof slope.

Secondary blocks. Portions of the building attached to the central mass of a building, generally such as additional wings, projections, dormers, or porches.

- more terms found in the Glossary, p. 42

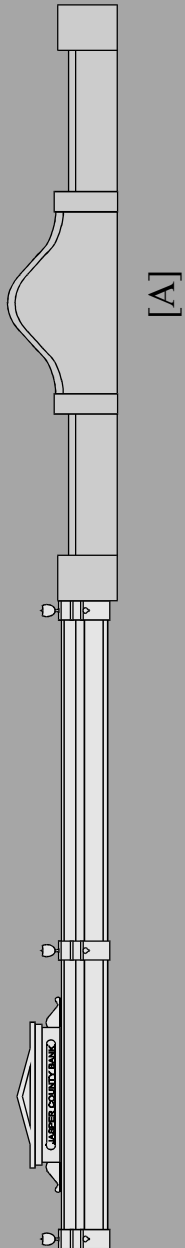

Common Mistakes

- ▶ *Constructing a parapet with a form or style atypical to the area. [A]*
- ▶ *Constructing a building with secondary blocks rather than one main block. [B]*
- ▶ *Constructing a building with a roof form unlike the established pattern. [C]*

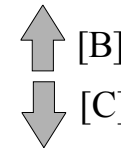
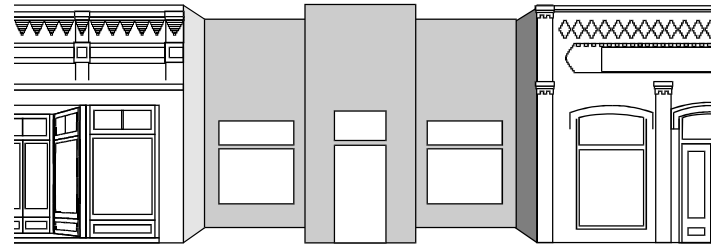

GOAL:

The primary goal is to follow the solid-to-void ratio characteristic of historic buildings in the district.

Actions to achieve the goal:

- ▶ New buildings should respect the pattern of openings on historic buildings by:
 - a) using openings of similar dimensions and shape,
 - b) placing or distributing openings in a manner similar to that of nearby similar historic buildings or similar buildings within the district, and
 - c) balancing the ratio of solid-to-void by using the appropriate amount of opening on an elevation.

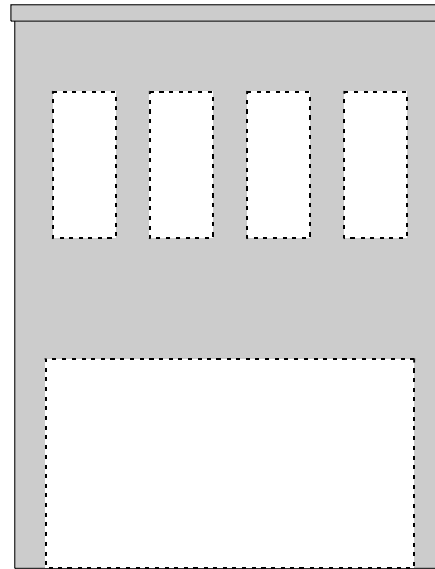

Downtown commercial buildings have a high degree of void at street level and evenly spaced smaller voids on upper floors.

Openings refers to windows and doors. Void is another term for openings.

Glossary terms:

Elevation.

Any of the external faces of a building.

Facade.

The front elevation or “face” of a building.

Nearby historic buildings.

The closest possible examples: 1) adjacent historic buildings, 2) historic buildings along the same street, 3) historic buildings within the immediate area, 4) historic buildings within the district.

Solid-to-void.

The total area of wall in comparison to the total area of openings on an elevation.

- more terms found in the Glossary, p. 42

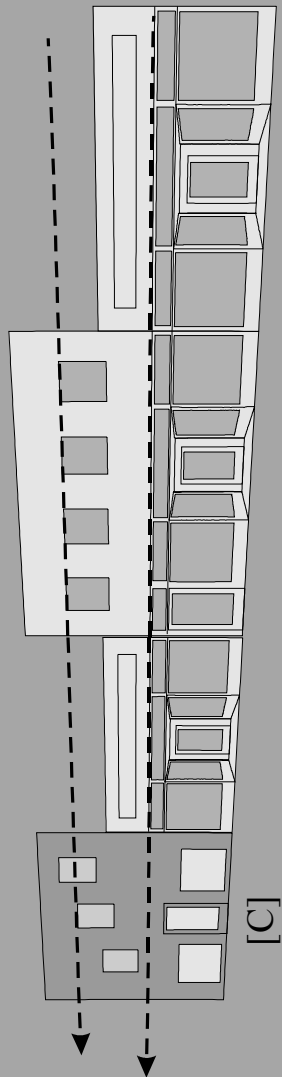

Common Mistakes

- ▶ *Using an asymmetrical distribution of windows and doors when symmetrical facades are the established pattern within that block. [A]*
- ▶ *Using a high solid-to-void ratio at ground level (the storefront) or a low solid-to-void ratio on upper floors. [B]*
- ▶ *Failing to align openings with other buildings on the same block. [C]*

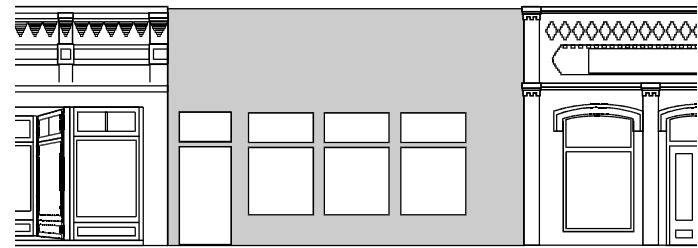

GOAL:

The primary goal is to follow the pattern of use of materials within the downtown district.

Actions to achieve the goal:

- ▶ New buildings should respect the historic materials within the district by using the predominant exterior material - namely brick.
- ▶ New buildings should respect the ornamentation within the district by:
 - a) using ornamentation in a manner similar to that of nearby similar historic buildings or similar buildings within the district, and
 - b) using ornamentation to a degree equal to or less than that of nearby similar historic buildings or similar buildings within the district.

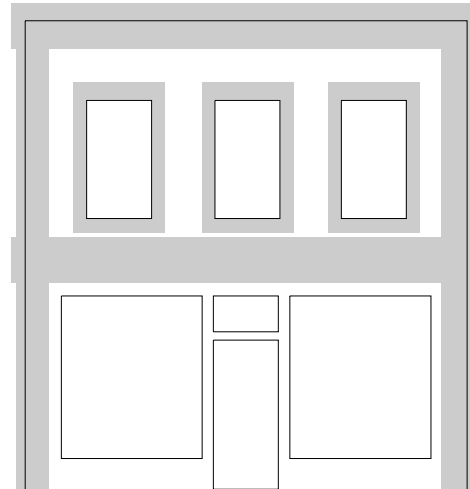

Shaded areas are traditional locations of ornament on commercial buildings.

Materials refers to the composition, texture, and appearance of the exterior surface of a building. **Details** refers to ornamentation that embellish the building.

Glossary terms:

Facade.

The front elevation or “face” of a building.

Nearby historic buildings.

The closest possible examples: 1) adjacent historic buildings, 2) historic buildings along the same street, 3) historic buildings within the immediate area, 4) historic buildings within the district.

Solid-to-void.

The total area of wall in comparison to the total area of openings on an elevation.

Synthetic stucco (EIFS).

Exterior insulation and finish systems (EIFS) are multi-component exterior wall systems which generally consist of: an insulation board; a base coat reinforced with glass fiber mesh ; and a finish coat.

Variiegated brick.

Multi-colored brick used in an attempt to create an antique look.

- more terms found in the Glossary, p. 42

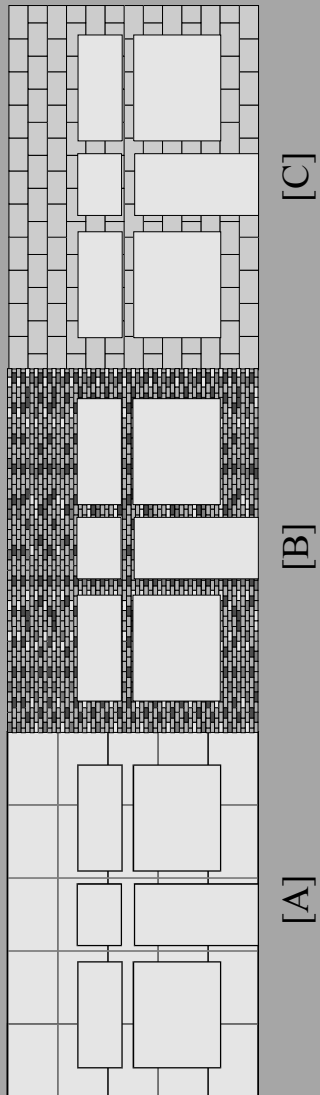

Common Mistakes

- ▶ *Using synthetic stucco (E.I.F.S.) [A]*
- ▶ *Using variegated brick . [B] or concrete block. [C]*
- ▶ *Using any material other than brick.*
- ▶ *Copying historic styles or themes not common to the area such as colonial or wild west. [D]*
- ▶ *Use of stock details which do not match the proportions and degree of craftsmanship of historic details.*

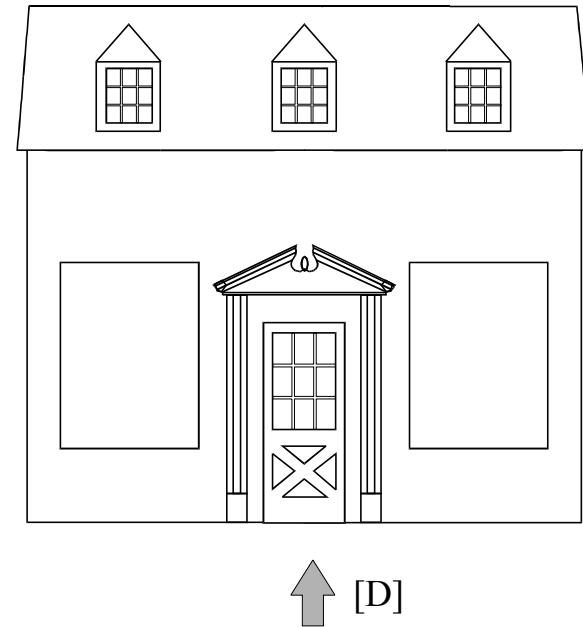

36 SITE & SETTING WALLS & FENCES

GOAL:

The primary goal is to maintain the pattern of fencing in the commercial area and to use fencing and walls to screen parking and storage areas.

Actions to achieve the goal:

- ▶ Historic fences and retaining walls should be maintained and not removed.
- ▶ New security fences should limit their impact by:
 - a) being placed behind the rear elevation, being no taller than 8 feet in height, and
 - b) using traditional materials (in most cases wood) or screening fence from the public view with evergreen vegetation or a second traditional fence.
- ▶ New screening walls can be used to limit the impact of parking on the district by:
 - a) being of a height to partially screen parked vehicles;
 - b) replicating the facade line of nearby historic buildings; and
 - c) using traditional materials (in most cases brick).

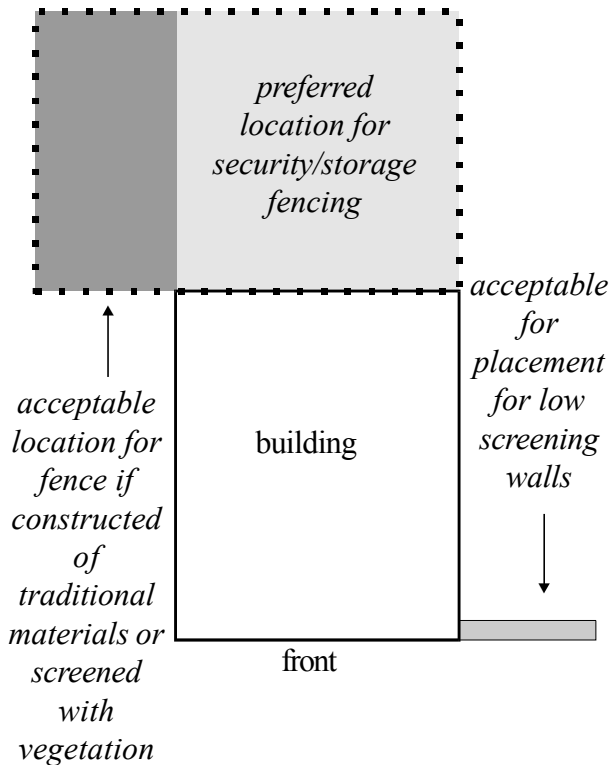

Walls and fences refers to nonvegetative elements used in and around a property for safety, security, and screening.

Glossary terms:

Elevation.

Any of the external faces of a building.

Evergreen vegetation.

Vegetation which retains foliage through the winter months maintaining its screening property.

Facade line.

An imaginary line established by the fronts of buildings on a block.

- more terms found in the Glossary, p. 42

Changes requiring a COA

Examples:

- * Construction of a new fence.
- * Construction of a new screening wall.

Changes not requiring a COA

Examples:

- * Repair of an existing fence.
- * Painting an existing fence.
- * Repair of an existing wall.
- * Temporary fences at construction sites.

Common Mistakes

- ▶ *Using nontraditional materials, such as metal chainlink, for fences. [A]*
- ▶ *Placing a privacy fence flush with the facade of a building. [B]*

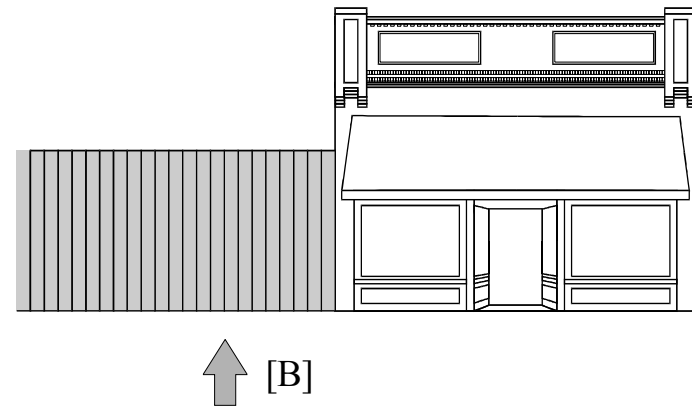
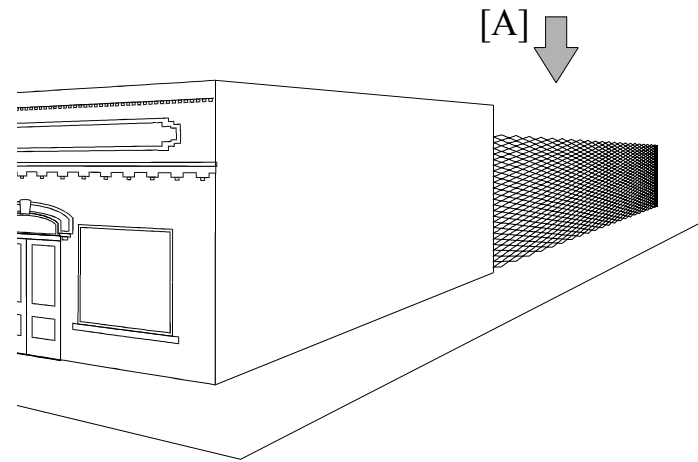

MODERN FEATURES

GOAL:

The primary goal is to integrate modern features while limiting the negative impact to the downtown district.

Actions to achieve the goal:

- ▶ Mechanical systems placed behind the building and out of the public view.
- ▶ Rooftop mechanical systems, utility meters and security lighting should be placed unobtrusively.
- ▶ New lighting should use traditional designs appropriate to the character of the building.
- ▶ New parking should:
 - a) be placed as unobtrusively as possible;
 - b) use traditional materials: concrete, stone pavers, and asphalt is allowed in the downtown; and
 - c) use appropriate screening (see *Walls & Fences* p. 50).

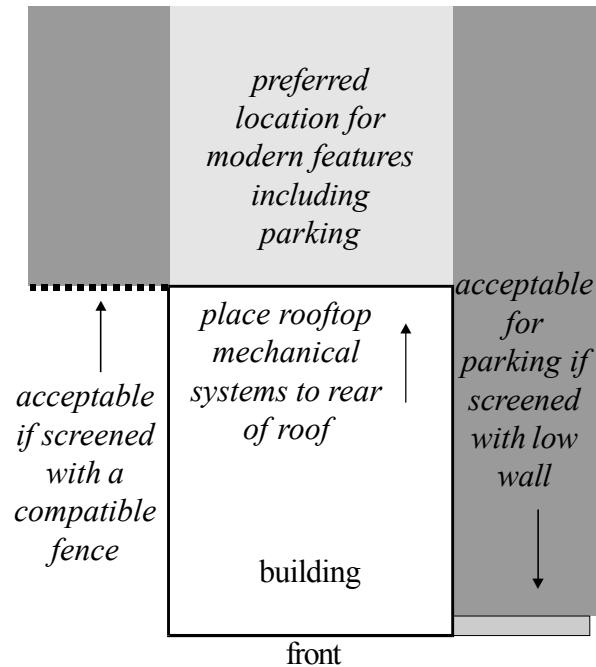

Modern features refers to equipment and functions not used in the past such as dumpsters, fire escapes, mechanical systems, and parking areas.

Glossary terms:

Facade line.

An imaginary line established by the fronts of buildings on a block.

Parking.

Areas, generally paved, provided for the storage of automobiles.

Paving.

Any material used for pavement such as asphalt, brick, concrete, gravel, or pavers.

Public view.

That which can be seen from any public right-of-way.

- more terms found in the *Glossary*, p. 42

Notes/Revisions:

Changes requiring a COA

Examples:

- * Adding parking areas.
- * Placing exterior mechanical systems such as satellite dishes, air-conditioning units, or utility meters.
- * Adding exterior lighting.

Common Mistakes

- ▶ *Demolishing historic buildings for parking (see demolition p.).*
- ▶ *Failing to screen parking from the public view (see Fences & Walls, p. 48) [A]*
- ▶ *Placing mechanical systems to the front of rooftops. [B]*

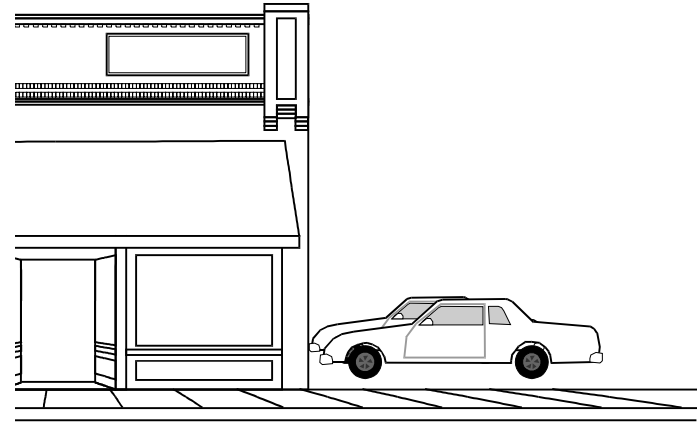

[A]

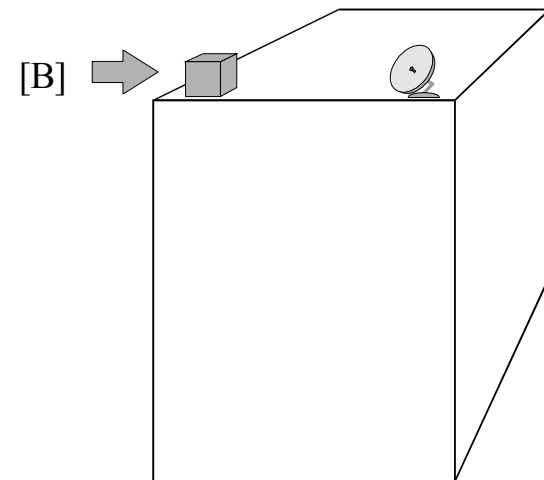

[B]

Changes not requiring a COA

Examples:

- * Resurfacing an existing parking area with the same material.
- * Interior changes to mechanical systems.
- * Temporary event lighting.

40 SITE & SETTING SIGNS

GOAL:

The primary goal is to create signs which both inform the public and compliment the property where they are located.

Actions to achieve the goal:

- ▶ Historic signs should be maintained and preserved
- ▶ Signs must conform to the City of Acworth sign ordinance and are to be approved on a case by case basis in the Historic Business District (HBD) through a formal review by one representative of HPC, DDA, and City staff.
- ▶ Signs should:
 - a) be limited in number to the minimum necessary for identification purposes,
 - b) use traditional sign locations,
 - c) be of a scale appropriate to the building and the district,
 - d) be painted wood or metal,
 - e) have little ornament or use ornament similar to the style of the building, and
 - f) avoid attachment to roofs or covering architectural details.

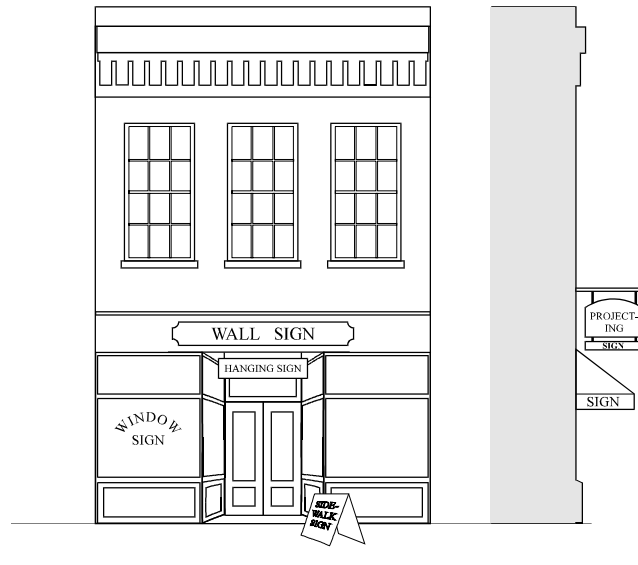

Signs refers to permanent signs for business identification, advertisement, and operation.

Glossary terms:

Cast iron front.

A storefront made of glass and pieces of utilitarian and decorative iron cast in easily assembled parts.

Corbeling.

A series of stepped or overlapped pieces of brick or stone forming a projection from the wall surface.

Cornice.

The uppermost, projecting part of an entablature, or feature resembling it.

Recessed panel.

A decorative element that often functions as an area for signage.

Transom.

A small operable or fixed window located above a window or door.

- more terms found in the Glossary, p. 42

Changes requiring a COA

Examples:

- * Placing a new sign on a building or property.

Changes not requiring a COA

Examples:

- * Placing temporary signs such as event, political, or real estate signs (as allowed under the City of Acworth sign ordinance).

Common Mistakes

- ▶ *Using more than two signs per building.*
- ▶ *Using internally lit plastic signs.*
- ▶ *Using unfinished wood, plastic substrate, or plywood signs.*
- ▶ *Using inappropriately large signs. [A]*
- ▶ *Using signs with a colonial motif. [B]*
- ▶ *Covering architectural details such as the cornice. [C]*
- ▶ *Painting over or stripping historic painted signs.*

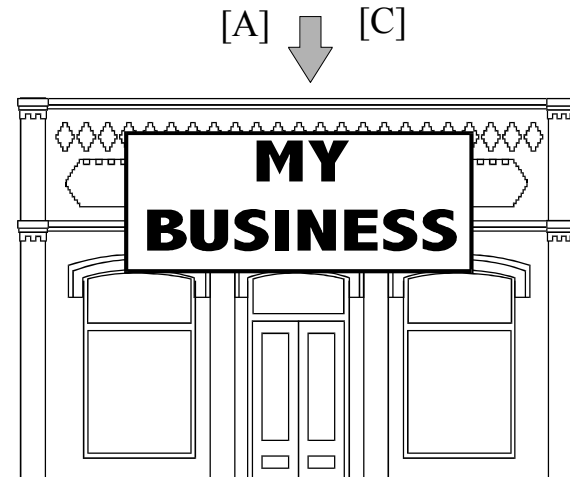

Addition. New construction added to an existing building or structure.

Alteration. Work which impacts any exterior architectural feature including construction, reconstruction, or removal of any building or building element.

Arch. A curved construction which spans an opening and supports the weight above it.

Awning. A sloped projection supported by a frame attached to the building facade or by simple metal posts anchored to the sidewalk.

Barrier free access. The provision of appropriate accommodations to ensure use of buildings by persons with disabilities.

Bay. The horizontal divisions of a building, defined by windows, columns, pilasters, etc.

Beyond repair. When such a large portion of an element is damaged that repair becomes infeasible, generally, but not specifically, more than 50%.

Bond. A term used to describe the various patterns in which brick is laid.

Bracket. A decorative support feature located under eaves or overhangs.

Bulkhead. The panel between framing members and beneath the display windows in a storefront; also known as a kickpanel or kickplate.

Canopy. A flat projection from the building facade or attached to the building facade to shelter the storefront and pedestrian traffic.

Capital. Topmost member of a column or pilaster.

Cast iron front. A storefront made of glass and pieces of utilitarian and decorative iron cast in easily assembled parts.

Character defining. An element whose design and material is associated with the age and style of a building and helps define its architectural style (e.g. tile roofing on Mission Style buildings).

Clapboard. A wood exterior siding applied horizontally and overlapped with the lower edge thicker than the upper.

Column. A vertical, cylindrical or square supporting member, usually with a classical capital.

Coping. The capping member of a wall or parapet.

Corbeling. A series of stepped or overlapped pieces of brick or stone forming a projection from the wall surface.

Cornice. The uppermost, projecting part of an entablature, or feature resembling it.

Course. A horizontal layer or row of stones or bricks in a wall.

Dentil. One of a series of small, square, tooth or block-like projections forming a molding.

Documentation. Evidence of missing elements or configurations of buildings such as architectural plans, historic photographs, or “ghosts” of missing elements.

Double hung window. A window having two sashes, one sliding vertically over the other.

Elevation. Any of the external faces of a building.

Entablature. The horizontal group of members supported by the columns, divided into three major parts, it consists of architrave, frieze, and cornice.

Evergreen vegetation. Vegetation which retains foliage through the winter months maintaining its screening property.

Facade. The front elevation or “face” of a building.

Facade line. An imaginary line established by the fronts of buildings on a block.

Fanlight. An semicircular or semi-elliptical window with radiating muntins suggesting a fan.

Fascia. A projecting flat horizontal member or molding; forms the trim of a flat roof or a pitched roof; also part of a classical entablature.

Fenestration. The arrangement of window openings in a building.

Finial. A projecting decorative element at the top of a roof, turret or gable.

Flashing. Thin metal sheets used to make the intersections of roof planes and roof/wall junctures watertight.

Footprint. The outline of a building’s ground plan from a top view.

Foundation. The lowest exposed portion of the building wall, which supports the structure above.

Frame construction. A method of construction in which the major parts consist of wood.

French door. A door made of many glass panes, usually used in pairs and attached by hinges to the sides of the opening in which it stands.

Frieze. The middle horizontal member of a classical entablature, above the architrave and below the cornice.

Gable roof. A pitched roof with one downward slope on either side of a central, horizontal ridge.

Gentlest means possible. The least abrasive, intrusive, damaging means of preserving historic material.

Historic mortar mix.

There are designated five mortar types. Typically, the repointing mortar for historic buildings will be a Type O or K mortar. Mortar specifications permit a range of proportions, but typical proportions by volume are: Type O - 1 part portland cement, 2 parts hydrated lime, and 9 parts sand; Type K - 1 part portland cement, 4 parts hydrated lime and 15 parts sand.

Hood molding. A projecting molding above an arch, doorway, or window, originally designed to direct water away from the opening; also called a drip mold.

Infill. New construction where there had been an opening before. Applies to a new structure such as a new building between two older structures or new material such as block infill in an original window opening.

In-kind. Using the exact same material when replacing a damaged element (e.g. using a wood element to replace a wood element).

Jack arch. An arch with wedge shaped stones or bricks set in a straight line; also known as a flat arch.

Jamb. The vertical side of a doorway or window.

Keystone. The top or center member of an arch.

Light. A single pane of glass.

Lintel. A horizontal beam over a door or window which carries the weight of the wall above; usually made of stone or wood.

Main block. The central mass of a building, generally excluding secondary blocks such as additional wings, projections, dormers, or porches.

Masonry. Brick, block, or stone which is secured with mortar.

Massing. A term used to define the overall volume of a building.

Modillion. A horizontal bracket, often in the form of a plain block, ornamenting, or sometimes supporting, the underside of a cornice.

Mortar. A mixture of sand, lime, cement, and water used as a binding agent in masonry construction.

Mullion. A heavy vertical divider between windows or doors.

Muntin. A secondary framing member to divide and hold the panes of glass in a window.

National Register of Historic Places. The nation's official list of buildings, sites, and districts which are important in our history or culture. Created by Congress in 1966 and administered by the states.

Nearby historic homes/buildings. The closest possible examples: 1) adjacent historic buildings, 2) historic buildings along the same street, 3) historic buildings within the immediate area, 4) historic buildings within the district.

Orientation. The direction that the building (usually includes the primary entrance) faces.

Parapet. A low protective wall located at the edge of a roof.

Parking. Areas, generally paved, provided for the storage of automobiles.

Party wall. A common, shared wall between two buildings; typical of downtown brick buildings.

Paving. Any material used for pavement such as asphalt, brick, concrete, gravel, or pavers.

Pediment. A triangular crowning element forming the gable of a roof; any similar triangular element used over windows, doors, etc.

Pier. A vertical structural element, square or rectangular in cross section.

Pilaster. A pier attached to a wall, often with capital and base.

Pitch. A term which refers to the steepness of roof slope.

Portico. A roofed space, open or partly enclosed, forming the entrance and centerpiece of the facade of a building, often with columns and a pediment.

Portland cement. A strong, inflexible (too much so for historic buildings) hydraulic cement used to bind mortar.

Proper repointing. Hand raking deteriorated mortar and duplicating old mortar in strength, composition, color, and texture as well as joint width and joint profile.

Public view. That which can be seen from any public right-of-way.

Quoins. Decorative blocks of stone or wood used on the corners of buildings.

Recessed panel. A decorative element that often functions as an area for signage.

Reveal. The vertical profile created by the lap of siding, window casings, muntins, door surrounds, etc.

Reversible. Constructing additions or new elements in such a manner that if removed in the future original form and material would be largely unchanged.

Routine maintenance. Any action performed in order to preserve a historic property including minor replacement of material with like material providing no change is made to the appearance of the structure or grounds.

Rhythm. The pattern created by the relationship of elements along a street or on individual buildings (e.g. buildings to the open space or windows to wall space).

Sash. The portion of a window that holds the glass and which moves.

Scale. A term used to define the proportions of a building in relation to its surroundings.

Secondary blocks. Portions of the building attached to the central mass of a building, generally such as additional wings, projections, dormers, or porches.

Setback. A term used to define the distance a building is located from a street or sidewalk.

Sidelight. A glass window pane located at the side of a main entrance way.

Siding. The exterior wall covering or sheathing of a structure.

Sill. The horizontal member located at the top of a foundation supporting the structure above; also the horizontal member at the bottom of a window or door.

Solid-to-void. The total area of wall in comparison to the total area of openings on an elevation.

Spacing. The distance between adjacent buildings.

Storefront. The street-level facade of a commercial building, usually having display windows.

Streetscape. The combination of building facades, sidewalks, street furniture, etc. that define the street.

Stucco. Any kind of plasterwork, but usually an outside covering of portland cement, lime, and sand mixture with water.

Surround. An encircling border or decorative frame, usually around a window or door.

Synthetic stucco (EIFS). Exterior insulation and finish systems (EIFS) are multi-component exterior wall systems which generally consist of: an insulation board; a base coat reinforced with glass fiber mesh; and a finish coat.

Transom. A small operable or fixed window located above a window or door.

Variegated brick. Multi-colored brick used in an attempt to create an antique look.

Vernacular. Indigenous architecture that generally is not designed by an architect and may be characteristic of a particular area. Any local adaptation of popular architectural forms.

Wrought iron. Decorative iron that is hammered or forged into shape by hand, as opposed to cast iron which is formed in a mold.